

CLIMMA COMPACT

the eco-friendly independent air-conditioner

- Self-contained independent air-conditioning systems from **3.500** up to **24.000 Btu/h**
- Ecologic refrigerant ensures efficiency and lower power consumption
- Very slim high-efficient heat exchanger
- Powerful and adjustable blowers
- Brass threaded condensation outlet pipe and dry pan Climma system



Climma Compact serie of independent air-conditioners are perfect for cooling single or adjacent cabins.

All Climma Compact range has been specifically designed for **nautical applications**, with water cooled high-efficiency coppernickel condensers, a very compact design, quiet and powerful blowers and an ecologic refrigerant.

They are supplied as standard with the reverse cycle option, but they are also available also with electrical heater.

I condizionatori indipendenti Climma Compact, sono perfetti per condizionare un singolo ambiente oppure ambienti contigui.

Studiati appositamente per **applicazioni nautiche**, raffreddati ad acqua tramite scambiatori in cupronickel marino ad alta efficienza, compatti, silenziosi e potenti, funzionano con refrigerante ecologico.

Forniti di standard con l'opzione inversione di ciclo, per poter riscaldare l'ambiente, sono disponibili anche in versione con riscaldamento elettrico.



ECOLOGIC REFRIGERANT
ENSURES EFFICIENCY



SLIM HIGH-EFFICIENT
HEAT EXCHANGER



POWERFUL AND
ADJUSTABLE BLOWERS



CLIMMA DRY PAN SYSTEM
AVOIDS CONDENSATION

	Compact 3.5	Compact 5	Compact 7	Compact 9	Compact 12	Compact 16	Compact 17	Compact 24
Capacity Cool (Btu/h)	3.500	5.000	7.000	9.000	12.000	16.000	17.000	24.000
Capacity Heat (Btu/h)	3.500	4.500	7.000	9.000	12.000	16.000	17.000	24.000
Net Weight (Kg)	12	25	26	26	31,5	40	42	45
Shipping Weight (Kg)	15	30	31	31	36,5	46	48	55
Duct Size (mm)	100	100	100	100	125	150	2x100	2x125
Max Air Flow (mc/h)	230	230	230	230	560	900	2x290	2x560
Size (WxDxH)*	381x204x227	520x300x295	425x315x316	520x300x295	523x330x340	605x368x352	800x398x330	800x398x415
Electrical heating - EH models (W)	N.A.	1300	1300	1300	1600	2000	1300x2	1300x2
Available power supply	230/1/50 230/1/60 115/1/60	230/1/50	230/1/50 230/1/60 115/1/60	230/1/50-60	230/1/50 230/1/60 115/1/60	230/1/50 230/1/60 115/1/60	230/1/50 115/1/60	230/1/50 230/1/60

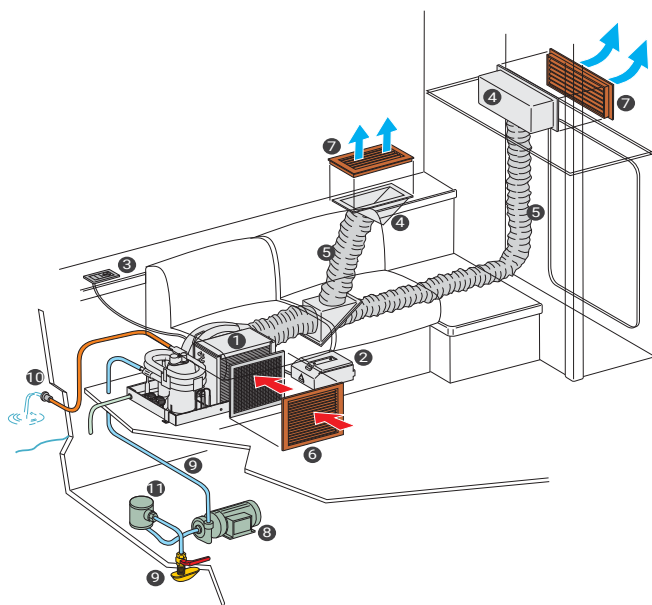

- 1 Climma Compact air-conditioner AIR-CONDITIONING
- 2 Climma Compact Control Box AIR-CONDITIONING
- 3 Climma Control Panel CONTROL PANEL
- 4 Plenums AIR KIT
- 5 Insulated ducts AIR KIT
- 6 Intake air grills AIR KIT
- 7 Delivery air grills AIR KIT
- 8 Sea water pump SEA WATER KIT
- 9 Sea water intake SEA WATER KIT
- 10 Sea water exit SEA WATER KIT
- 11 Water filter SEA WATER KIT

CONTROL PANELS



C-TOUCH THERMOSTAT



MK2 THERMOSTAT



MK3 THERMOSTAT

AIR AND SEA WATER KITS

All our compact systems can be easily installed with our premade kits for air and sea water.

Air kits contain all the accessories necessary for the air-distribution of the Compact system, in details:

- Pre-insulated flexible air duct
- Duct-plenum connection nipples
- Plenum for air supply grill
- Return and supply air grilles

Water kits contain accessories needed to connect the system to the sea water, in details:

- Sea water intake
- Sea water filter
- Valves
- Sea water outlet

Tutti i condizionatori Compact possono essere installati facilmente con dei semplici kit di installazione aria e acqua.

I Kit aria comprendono tutto il necessario per la distribuzione dell'aria di mandata e di ripresa, ed includono:

- Condotta aria pre-isolata e flessibile
- Raccordi condotta-plenum
- Plenum di alloggio griglie di mandata
- Griglia di mandata e di ripresa

I Kit acqua comprendono invece tutti gli accessori necessari per collegare l'impianto all'acqua di mare, in particolare:

- Presa mare
- Filtro acqua mare
- Rubinetti
- Scarico acqua mare